



CLUBE NAVAL

DE CASCAIS

20 > 25 AUG



## SAILING INSTRUCTIONS

### Snipe Class International Racing Association Cascais 2022 Snipe World Championship Commodore Hub E. Isaacks Trophy 18th to 25th August Clube Naval de Cascais Cascais

#### Notation [NP]

The notation [NP] in a rule in the SI means that a breach of this rule shall not be grounds for a protest by a boat.

#### Notation [SP]

The notation [SP] in a rule in the SI means that for a breach of this rule a standard penalty will be applied.

#### 1 RULES

The regatta will be governed by:

- 1.1 The rules as defined in the Racing Rules of Sailing (RRS) 2021 - 2024
- 1.2 The SCIRA Rules of Conduct for Conducting National and International Championship Regattas (RoC) available at [https://www.snipe.org/images/2021/SCIRA\\_2021\\_Rules\\_of\\_Conduct\\_final.pdf](https://www.snipe.org/images/2021/SCIRA_2021_Rules_of_Conduct_final.pdf)
- 1.3 The Deed of Gift, available at [https://www.snipe.org/images/2021/Isaacks\\_World\\_Championship\\_2021-final\\_enhanced.pdf](https://www.snipe.org/images/2021/Isaacks_World_Championship_2021-final_enhanced.pdf)
- 1.4 **Only the following** Portuguese Federation Prescriptions will apply:
  - RRS 67** - The Portuguese Sailing Federation prescribes,
    - a) A boat that takes a penalty or retires does not thereby admit liability for damages or that she broken a Rule.
    - b) Any claim for damages arising from an incident while a boat is bound by The Racing Rules of Sailing shall be subject to the jurisdiction of the courts and not considered by a Protest Committee or Appeals Committee.
  - RRS 86.3** - The Portuguese Sailing Federation prescribes that at any event under its jurisdiction, if the Race Committee intends to test or develop a Rule, this shall only be allowed if prior written authorization is given by the Race Officials Committee from the Portuguese Sailing Federation and with the obligation of reporting, by writing, any result.
  - RRS 88.2** - The Portuguese Sailing Federation prescribes that a Notice of Race and Sailing Instructions will not change its prescriptions. However, when an International Jury is approved to one event, only the prescriptions to the Rules 60.1, 67, 86.3, 88.2 and 91(b) will apply.
  - RRS 91(b)** - The Portuguese Sailing Federation prescribes that, at any event under its jurisdiction, an International Jury has to be approved by the Race Officials Committee of the Portuguese Sailing Federation, with the exception of the events described on this Rule.
- 1.5 The decision of the jury will be final in accordance with RRS 70.5.
- 1.6 RRS Appendix P will apply, except that P2.3 is deleted and P2.2 will apply on subsequent penalties
- 1.7 RRS Appendix T will apply.
- 1.8 RRS 35 and RRS 63.1 will be changed to provide that, boats not finishing within 30 minutes after the first boat to finish will be scored "Did Not Finish" without a hearing.
- 1.9 RRS 60.1(a) will be changed to restrict protest from boats for specific items on the NR and SI.
- 1.10 RRS 32.1 and RRS 64.3 will be changed to compel the Jury/RC to abandon a race as required by SCIRA RoC 18.
- 1.11 If there is a conflict between languages the English text will take precedence.
- 1.12 No drones are allowed closer than 500 m from racing areas from the Warning Signal for a race and after the last boat has finished the race. This does not apply to OA drones.

#### 2 NOTICES TO COMPETITORS

Notices to competitors will be posted on the official notice board(s) located online:  
<https://www.racingrulesofsailing.org/documents/4624/event>

#### 3 CHANGES TO SAILING INSTRUCTIONS

- 3.1 Any change to the sailing instructions will be posted 120 minutes before the first warning signal of the first race of the day it will take effect, except that any change to the schedule of races will be posted until 20h00 or until the protest time limit, whichever is later, on the day before it will take effect.
- 3.2 Any change or amendment to the Sailing Instructions shall be approved with the SCIRA Representative.

**4 SIGNALS MADE ASHORE**

- 4.1 Signals made ashore will be displayed at the Mast Pole at the south pier of Clube Naval de Cascais.
- 4.2 When the “AP” race signal is displayed ashore, ‘1 minute’ is replaced with ‘not less than 60 minutes’ in the race signal “AP”.
- 4.3 [NP] [DP]. When the “AP over H” race signal is displayed ashore, the boats shall not leave the harbour. The warning signal will be exposed no less than 60 minutes after the signal is lowered with one sound

**5 SCHEDULE OF RACES**

**5.1 Dates of racing:**

Schedule of Races:

August 20<sup>th</sup> – Practice Race 1<sup>st</sup> Warning Signal at 14h00.

August 21<sup>st</sup> to 25<sup>th</sup> – 1<sup>st</sup> Warning Signal is TBA.

- 5.2 The regatta shall consist of 9 races. Three races constitute the regatta.
- 5.3 No more than two (2) races shall be sailed per day; three (3) races can be sailed only if behind schedule.
- 5.4 In case of a prolonged postponement, to alert boats that a race or sequence of races will begin soon, an orange flag will be displayed with one sound for at least four minutes before a warning signal is made. Failures to observe this instruction are not grounds for redress.
- 5.5 There will be a competitors briefing every day, at event tent 2 hours before the first warning signal of that day.

**6 CLASS FLAGS**

The official Class Flag shall be the Snipe Class flag, a black Snipe on a white background.

**7 RACING AREAS**

The Racing Area location chart is posted on the Official Notice Board

**8 WEATHER LIMITATION (Course and Starting)**

The wind speed ranges shall be in accordance with the Rules of Conduct for Conducting National and International Championships and the applicable Deed of Gift for Snipe World Championships.

**9 THE COURSES**

- 9.1 The diagrams below show the courses, including the approximate angles between legs, the order in which marks are to be passed. All course marks (except gates) shall be left to port.

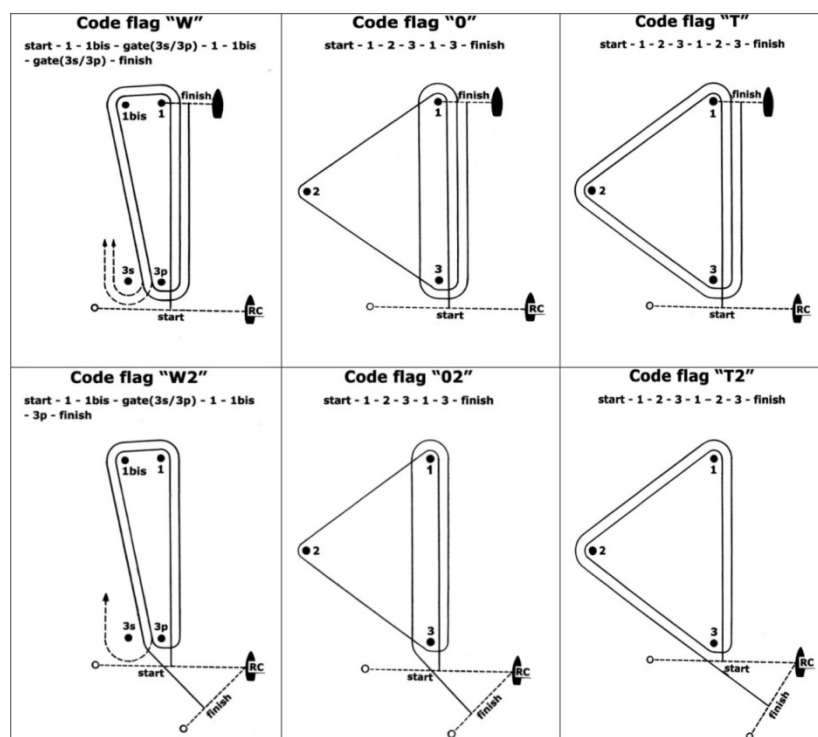

- 9.2 The course signal Flags (flag from ICS “W”, “T”, “O”, “W2”, “T2” or “O2”) shall be hoisted with no sound signal no later than the warning signal. It will remain displayed for not less than five minutes after the start.



CLUBE NAVAL

DE CASCAIS

20 > 25 AUG



- 9.3 No later than the warning signal, the Race Committee signal boat will display the approximate compass bearing of the first leg.
- 9.4 If during a race the wind and/or wave action changes to the point where the selected course would be inadvisable (See Course Selection Diagram), the Race Committee shall change the course at any mark. A change of the type of course during the race shall be signaled displaying the new appropriate flag and accompanied by repetitive sounds before the leading boat has passed or rounded the mark.
- 9.5 A sustained wind variation of 20 degrees or more from the posted bearing during the first leg of a race shall result in the race to be abandoned and re-sailed, or abandoned. This changes the RRS 32.1.
- 9.6 A sustained wind variation of 40 degrees or more from the posted bearing during the first lap shall result in the race being abandoned and re-sailed, or abandoned. For the purpose of this rule a lap means the rounding of mark 3 (or passing the gate 3s-3p) for the first time. This changes the RRS 32.1.
- 9.7 The number of legs in a race may be reduced (RRS code flag S) but at least 2 (two) windward legs of the race shall be completed. This changes the RRS 32.2.
- 10 MARKS
- 10.1 Marks 1, 1bis, 2, 3, 3s and 3p will be Conical Red.
- 10.2 New marks, as provided in instruction 12.1, will be Conical Yellow
- 10.3 The port-end starting mark will be:  
a) a boat with an orange flag displayed;
- 10.4 The finishing mark will be:  
- mark 1 for "W", "O", and "T" courses;  
- a buoy with a Blue flag displayed for "W2", "O2", and "T2" courses
- 10.5 A Race Committee vessel signaling a change of a leg of the course is a mark as provided in SI 12.2.
- 10.6 If one of the marks "gate 3s-3p" is not placed, or is not replaced as per RRS 34, the remaining mark shall be left to port. This changes the RRS 34.
- 11 THE START
- 11.1 RRS 30.4 will be changed so that it will be applied in fleet with more than 45 boats and after the 2<sup>nd</sup> General Recall only
- 11.2 The starting line will be between a staff displaying an orange flag on the Race Committee vessel at the starboard end and: a staff displaying an orange flag on the starting mark as provided in instruction 10.3 a).
- 11.3 A boat starting later than 5 minutes after her starting signal will be scored Did Not Start without a hearing. This changes Appendices A4 and A5.
- 11.4 The Race Committee, after the finish of a race and before the warning signal of a subsequent one, will do its best to post on the Race Committee vessel a list of OCS, or ZPF, UFD or BFD boats. The failure of posting or an incomplete or wrong list will not be grounds for redress. This changes the RRS 62.1(a).
- 12 CHANGE OF THE NEXT LEG OF THE COURSE
- 12.1 To change the next leg of the course, the Race Committee will lay a new mark (or move the gate or the finishing line) and remove the original mark as soon as practicable. When in a subsequent change a new mark is replaced, it will be replaced by an original mark.
- 12.2 Except at a gate, boats shall pass between the race committee boat signaling the change of the next leg and the nearby mark, leaving the mark to port and the Race Committee vessel starboard. This changes the RRS 28.
- 12.3 After the completion of first windward leg of the race the remaining legs may be increased or decreased by not more than 30% of the original length. This changes the RRS 33.
- 12.4 If Mark 1 will be changed in courses "W" or "W2", Mark 1bis (offset) will no longer be a course mark.
- 13 THE FINISH
- 13.1 The finish line will be between a staff displaying an orange flag on a Race Committee vessel and the course side of the finishing mark. This changes Race Signals.
- 13.2 The A flag on the Race Committee boat at the finish means that there will be no more races for the day.
- 14 PENALTY SYSTEM
- 14.1 Appendix P will apply.
- 14.2 P2.3 is deleted and P2.2 will apply on subsequent penalties



CLUBE NAVAL

DE CASCAIS

20 > 25 AUG



## 15 TIME LIMITS AND TARGET TIMES

- 15.1 The races will be managed to last 60-75 minutes for the first boat to finish. A different time (shorter or longer) used to complete the race will not be ground for requesting redress.
- 15.2 The time limit for the first boat to complete the first lap is 40 minutes from the start. If the first boat fails to complete the first lap within 40 minutes the Race Committee shall abandon the race. For the purpose of this rule a lap means the rounding of Mark 3 (or passing the Gate 3s/3p) for the first time.
- 15.3 The time limit for the first boat to finish the race shall be 120min. Any boat finishing more than 30 minutes after the first boat finishes or failing to finish within 2 hours from the start, whichever is shorter shall be scored Did Not Finish (DNF). This changes RRS 35, A4 and A5.

## 16 PROTESTS AND REQUESTS FOR REDRESS

- 16.1 Protest forms are available at the race office, located at 1<sup>st</sup> floor of Club. Protests and requests for redress or reopenings shall be delivered there or at the following [link](#) within the appropriate time limit.
- 16.2 The protest time limit is 90 minutes after the last boat has finished the last race of the day or the Race Committee signals no more racing today, whichever is later.
- 16.3 Notices will be posted no later than 30 minutes after the protest time limit to inform competitors of hearings in which they are parties or named as witnesses. Hearings will be held in the protest room, located near the office
- 16.4 A list of boats that have been penalized for breaking RRS 42 will be posted on the Official Notice Board.
- 16.5 A list of boats that have been penalized for breaking RRS 29.1(OCS) or 30.1(OCS) or 30.2(ZPF) 30.3(UFD) and 30.4 (BFD) will be posted on the Official Notice Board.
- 16.6 Breaches of rules in the SI marked with [NP] and NoR 3.4 (bow numbers) will not be grounds for a protest by a boat. This changes the RRS 60.1(a).
- 16.7 The penalty for breaking rules in the SI marked with [SP] and NoR 3.4 (bow numbers) may be applied at the discretion of the Race Committee, without a hearing, and shall be the 5% scoring penalty for nearest race completed by the infringing boat but not worse than the number of points corresponding to DSQ. This changes the RRS 63.1 and the App.A5.
- 16.8 Penalties for breaking Class Rules may be less than disqualification.
- 16.9 A list of boats that have been penalized as per SI 16.7 and 16.8 will be posted on the Official Notice Board.
- 16.10 Measurement and equipment. SCIRA may refer any issue to the International Jury for advice.
- 16.11 The use of team racing tactics shall not be tolerated.
- 16.12 For the purpose of RRS 64.4(b) the “authority responsible” is the Measurer of the event.

## 17 SCORING

- 17.1 Three races are required to be completed to constitute a series.
- 17.2 (a) When fewer than 4 races have been completed, a boat’s series score will be the total of her race scores.  
(b) When from 4 to 9 races have been completed, a boat’s series score will be the total of her race scores excluding her worst score.

## 18 [NP][SP][DP] SAFETY REGULATIONS

- 18.1 Before the warning signal of the first race of the day each boat is required to sail past the stern of the Committee boat signal boat on starboard tack and verbally check in.
- 18.2 A boat that retires from a race shall notify the Race Committee as soon as possible.

## 19 REPLACEMENT OF CREW OR EQUIPMENT

- 19.1 The same crew shall race in all races, except for reasons satisfactory to the Race Committee. Requests for a change of crew shall be submitted in writing to the Chairman. Once a crew has been excused, he/she may not return for the balance of the series.
- 19.2 The same skipper shall sail all races and can be replaced after the first race only, and then only if he/she is obviously incapacitated. If a skipper is replaced the first race shall be the race dropped, or scored DNC.
- 19.3 [DP] Substitution of damaged or lost equipment will not be allowed unless authorized by the Technical Committee. Requests for substitution shall be made to the Technical Committee at the first reasonable opportunity.

## 20 [NP] EQUIPMENT AND MEASUREMENT CHECKS

A boat or equipment may be inspected at any time for compliance with the Class Rules and Sailing Instructions. On the water, a boat can be instructed by a member the Technical Committee, or the equipment inspector or measurer, to proceed immediately to a designated area for inspection.

## 21 [NP][SP] EVENT ADVERTISING

Boats shall display event advertising supplied by the organizing authority as follows:



CLUBE NAVAL

DE CASCAIS

20 > 25 AUG



Stickers are to be placed less than 30 cm from the bow and less than 5 cm from the deck rail

## 22 OFFICIAL BOATS

Official boats will be marked as follows:

Race Committee – RC on white flags

Jury – Jury on white Flags

Press – Press on Yellow Flags

## 23 [NP] [DP] SUPPORT BOATS

23.1 At the preparatory signal, coaches must be positioned at least 100 meters below the starting line. After the starting signal coaches may follow the fleet, but only on the port side of the course and must stay 50 meters from any mark

23.2 Coaches shall not communicate with competitors after the warning signal for any race until after the competitors have finished the race.

23.3 Coaches shall register at the Regatta Office and all support boats shall be identified Number on White Flags

## 24 [DP] RADIO COMMUNICATIONS

A boat that is racing shall not make voice or data transmissions and shall not receive voice or data communication that is not available to all boats, except in an emergency or when using equipment provided by the race committee

## 25 [DP] DRONES

No drones are allowed closer than 500 m from racing areas from the Warning Signal for a race and after the last boat has finished the race. As a penalty for breaching this rule the protest committee may impose a discretionary penalty (DP) to all boats associated with the owner / operator of the drone. This does not apply to OA drones.

## 26 [NP] [DP] TRASH DISPOSAL

Trash may be placed aboard support and Committee Vessels.

## 27 PRIZES

Prizes shall be awarded as provided by NoR.

José Cancellla - Race Committee Chairman

Luis Soubie - SCIRA Representative